

# Service Schematics

# NOKIA N95

## RM-159/RM-245

## Introduction

### IMPORTANT:

This document is intended for use by authorized NOKIA service centers only.

“Service Schematics” was created with focus on customer care. The purpose of this document is to provide further technical repair information for NOKIA mobile phones on Level 3/4 service activities. It contains additional information such as e.g. “Component finder”. The “Signal overview” page gives a good and fast overview about the most important signals and voltages on board. Saving process time and improving the repair quality is the aim of this document. It is to be used additionally to the service manual and other training or service information such as Service Bulletins.

### All measurements were made using following equipment:

Nokia repair SW : Phoenix version 2006.34.2.156  
Oscilloscope : Fluke PM 3380A/B  
Spectrum Analyzer : Advantest R3162 with an analog probe  
RF-Generator / GSM Tester : Rhode & Schwarz CMU 200  
Multimeter : Fluke 73 Series II

While every endeavour has been made to ensure the accuracy of this document, some errors may exist. If the reader finds any errors, NOKIA shall be notified in writing.

Please send E-Mail to: [training.sace@nokia.com](mailto:training.sace@nokia.com)



### A NEW FEATURE FOR ON-LINE USE

We have now linked those measurement points ① which are related to the oscillograms shown on the signal overview page. As example: clicking on the measurement point ① guides you to the matching oscillogram on the signal overview page. The next click onto the now shown signal guides you to the related measurement point on the module. Finally, a third click, now onto the measurement point ① on the module, takes you back to the starting point inside the schematics.

Do you have further improvement ideas or would like to give us feedback?  
Please send an email to: [training.sace@nokia.com](mailto:training.sace@nokia.com)

### Table of Content

Front page	1
AV connector	2
AVilma, Betty	3
Rapido, Memories, GPS	4
Menelaus, microSD	5
OMAP	6
Camera, HWA	7
WLAN, Bluetooth	8
UI, illumination	9
Slide PWB	10
RF part (RM-159)	11
RF part (RM-245)	12
Signal overview	13
Component finder (RM-159)	14
Component finder (RM-245)	15

Copyright © NOKIA

This material, including documentation and any related computer programs is protected by copyright, controlled by NOKIA. All rights are reserved. Copying, including reproducing, modifying, storing, adapting or translating any or all of this material requires the prior written consent of NOKIA. This material also contains companyconfidential information, which may not be disclosed to others without the prior written consent of NOKIA.

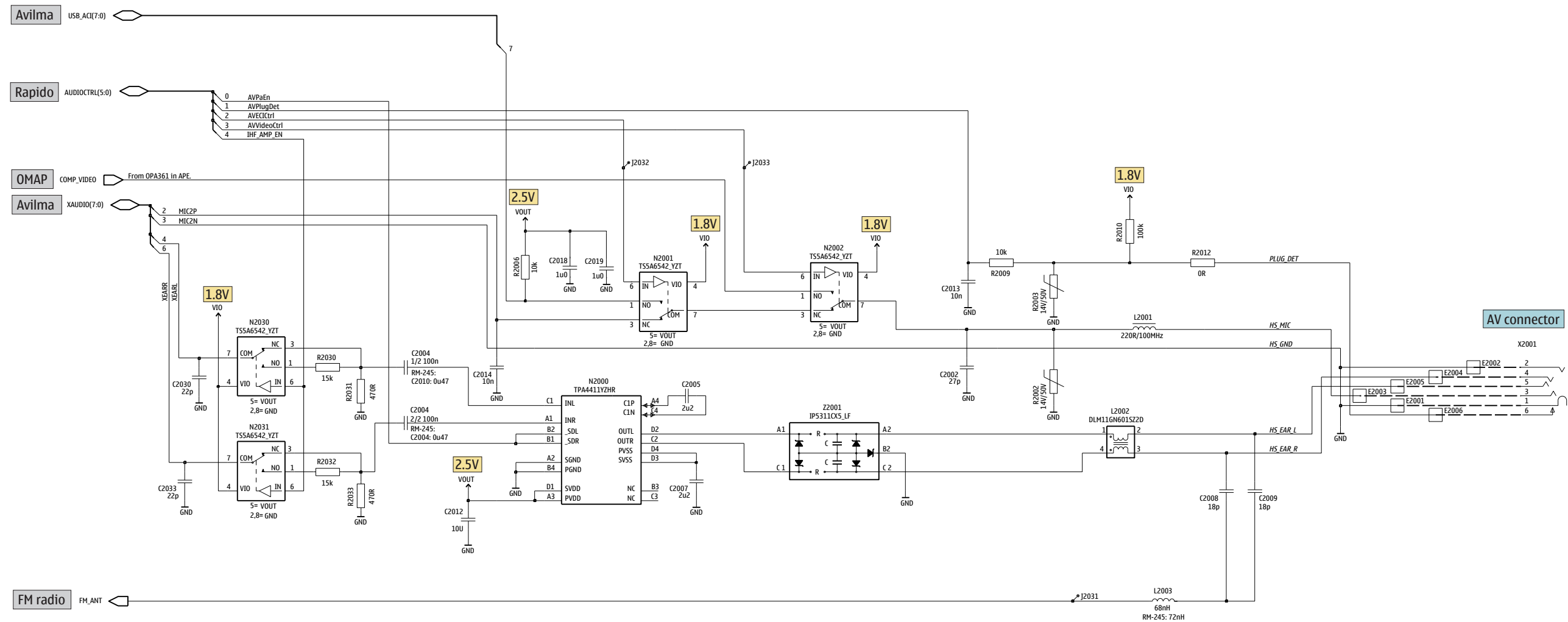

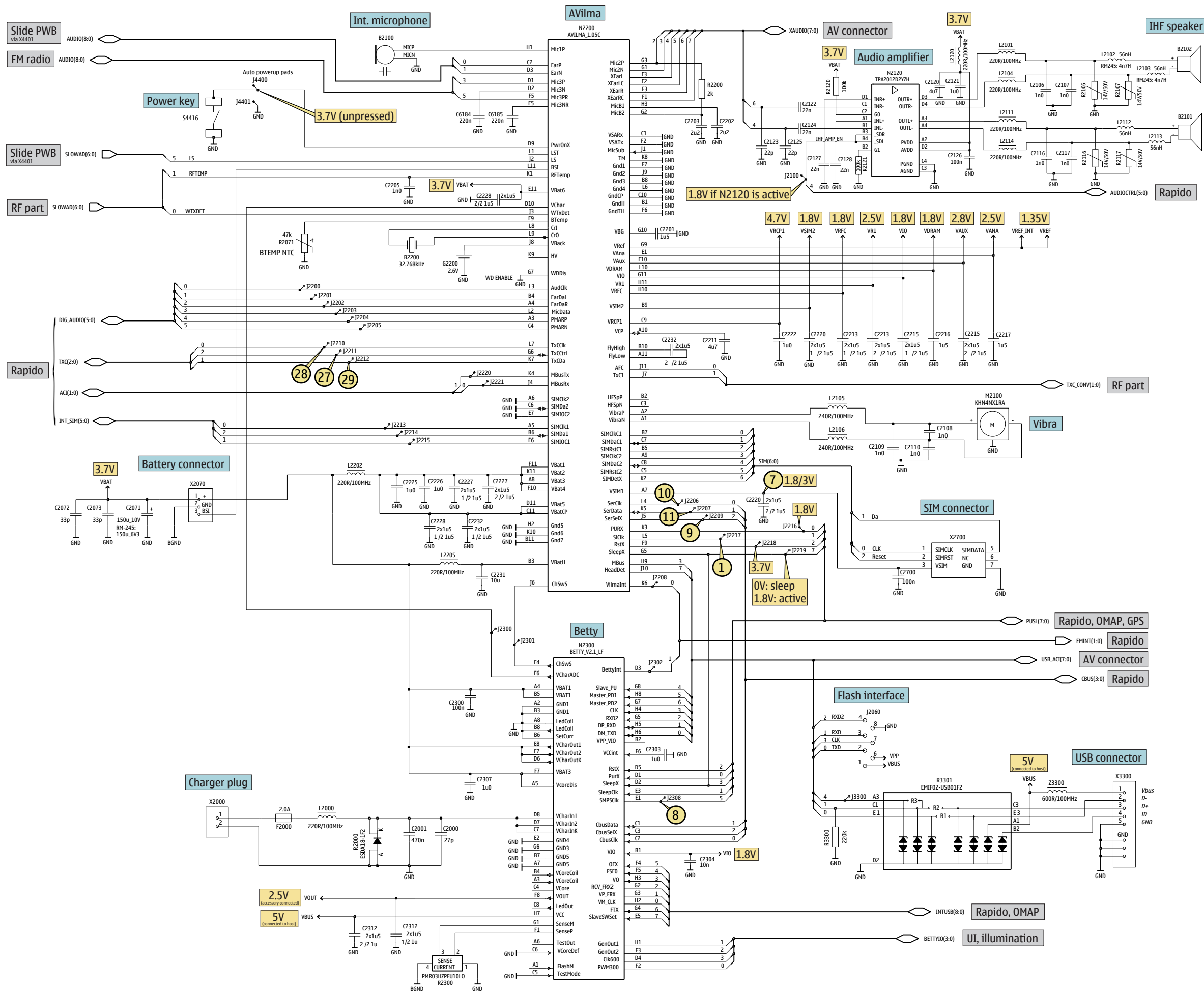

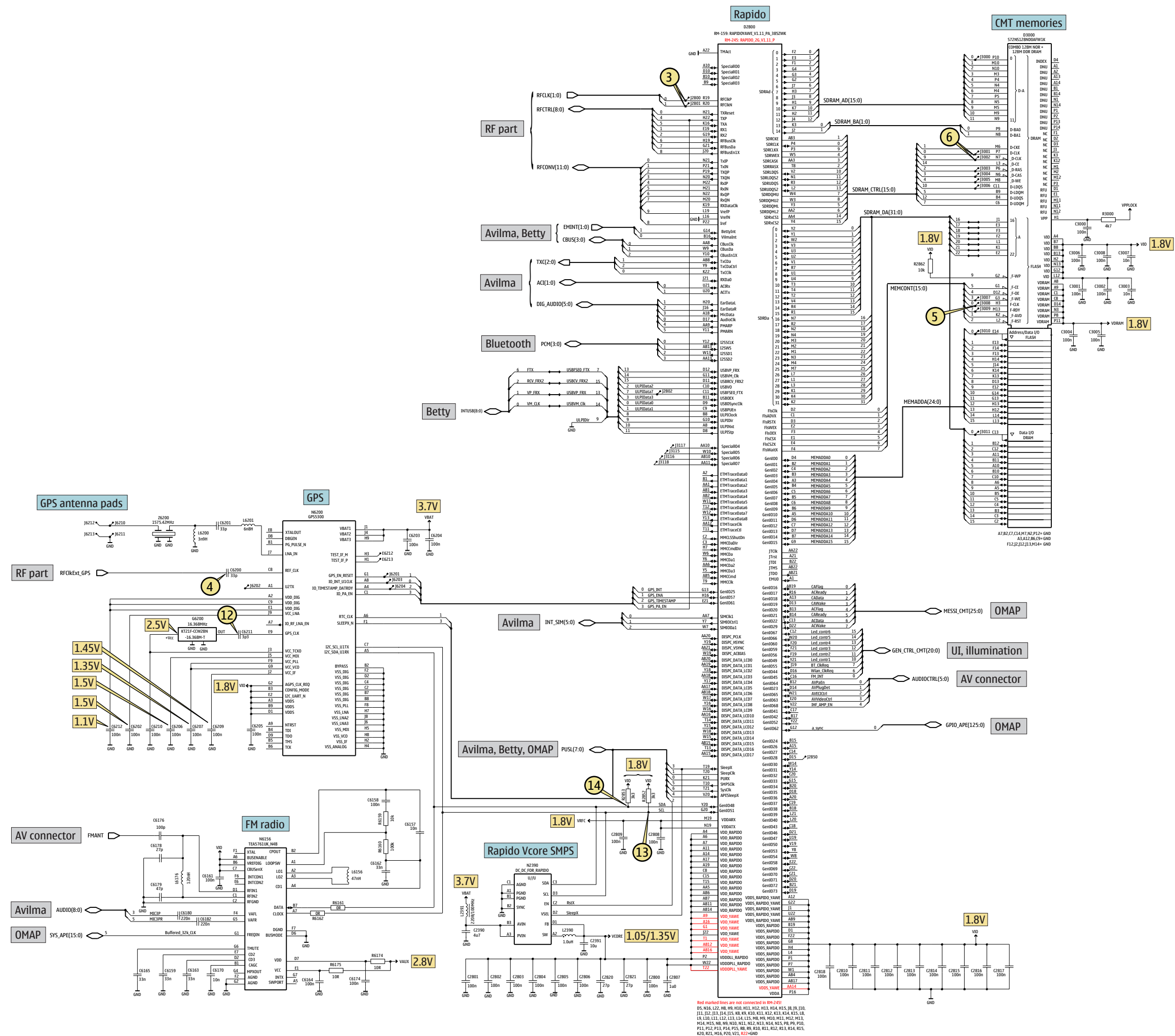

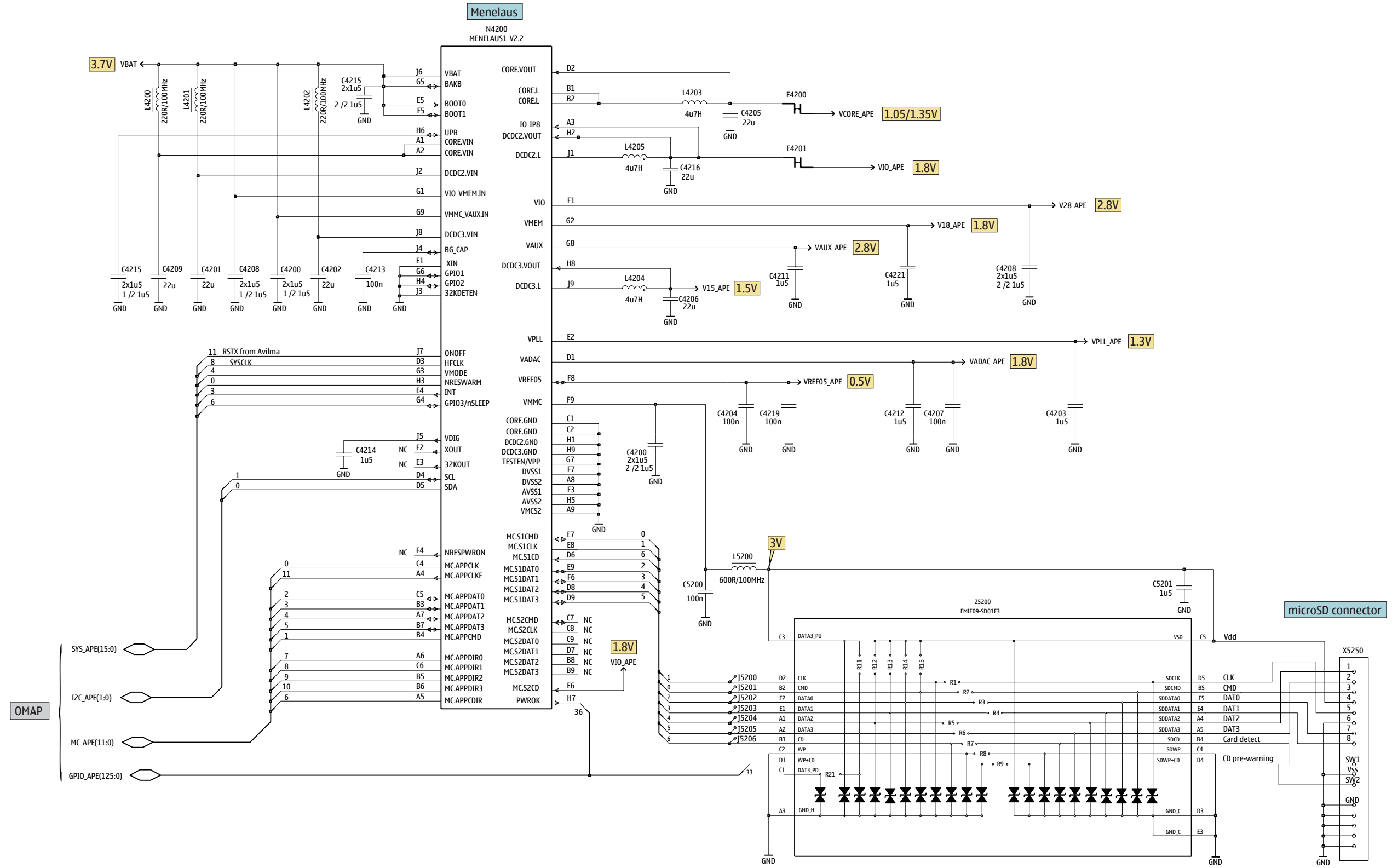

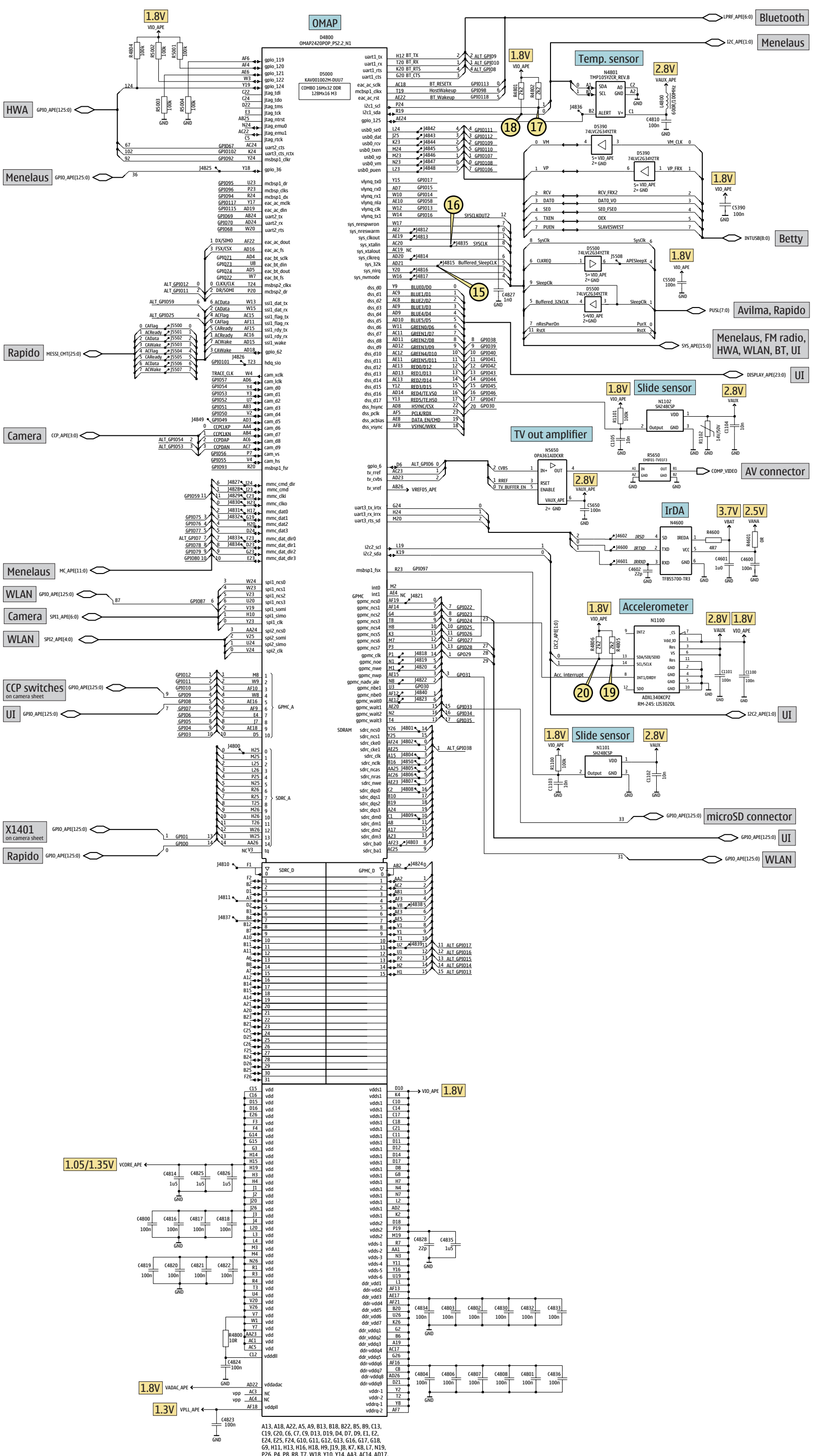

A13, A18, A22, A5, A9, B13, B18, B22, B5, B9, C13, C19, C20, C6, C7, C9, D13, D19, D4, D7, D9, E1, E2, E4, E25, F24, G10, G11, G12, G13, G16, G17, G18, G9, H11, H13, H16, H18, H9, J19, J8, K7, K8, L7, N19, P26, P4, P8, R8, T7, W18, Y10, Y14, A3, A4, A14, AD17, LB, C4, D20, D3, AC21, B1, A1, AF26, A26, B26, AE1, AF17, AF2, AF25, A25, AF2, AE26, AD1, AB23, K1, AE14, AF17, AE21, A16, U25, K25, G1, A4, W19, B17, G25, AF20, C3, AD25, N20, W2, R2, AC10, AE7=GND

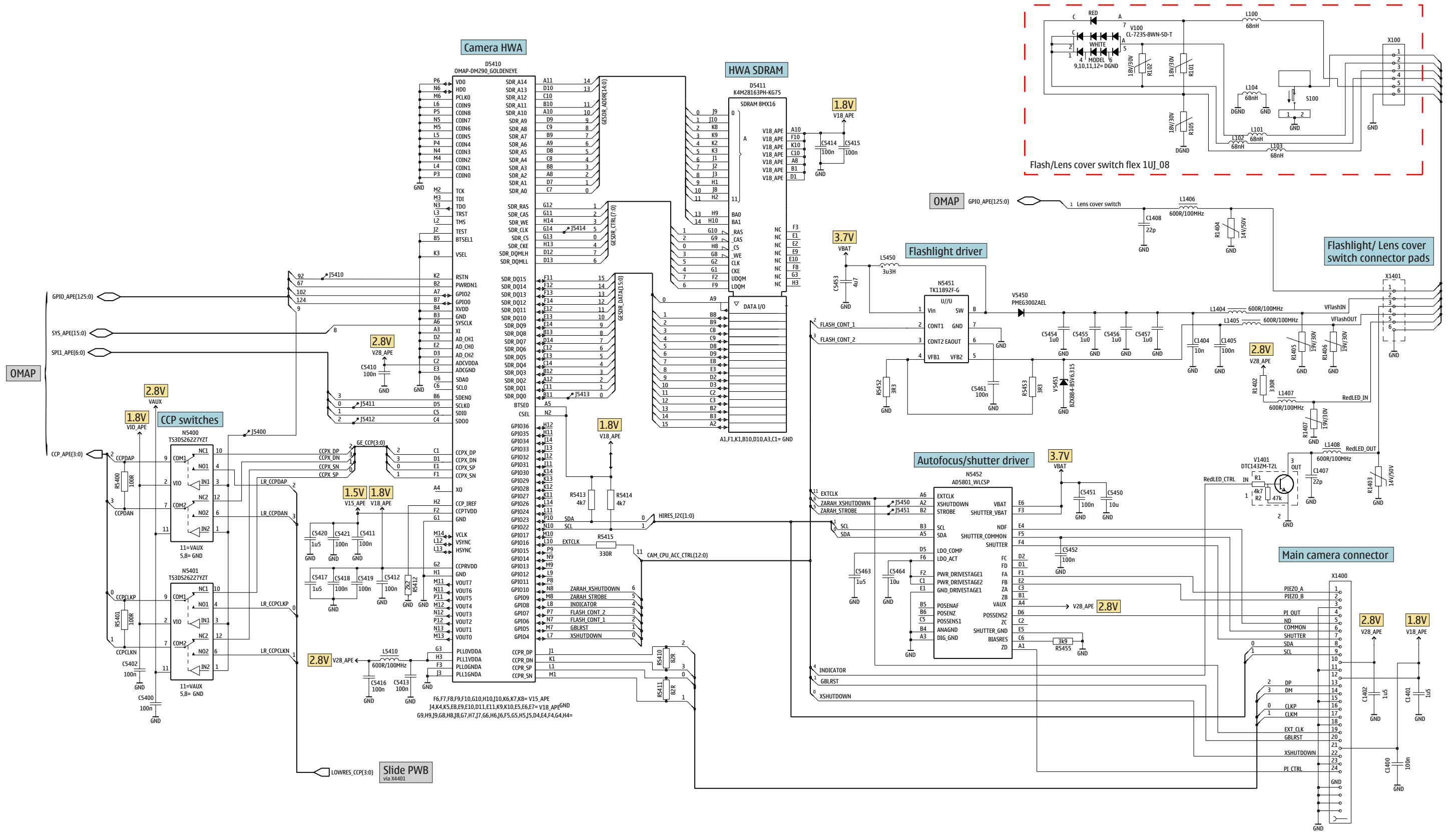

Please note:

All parts in this area are not assembled in RM-245!

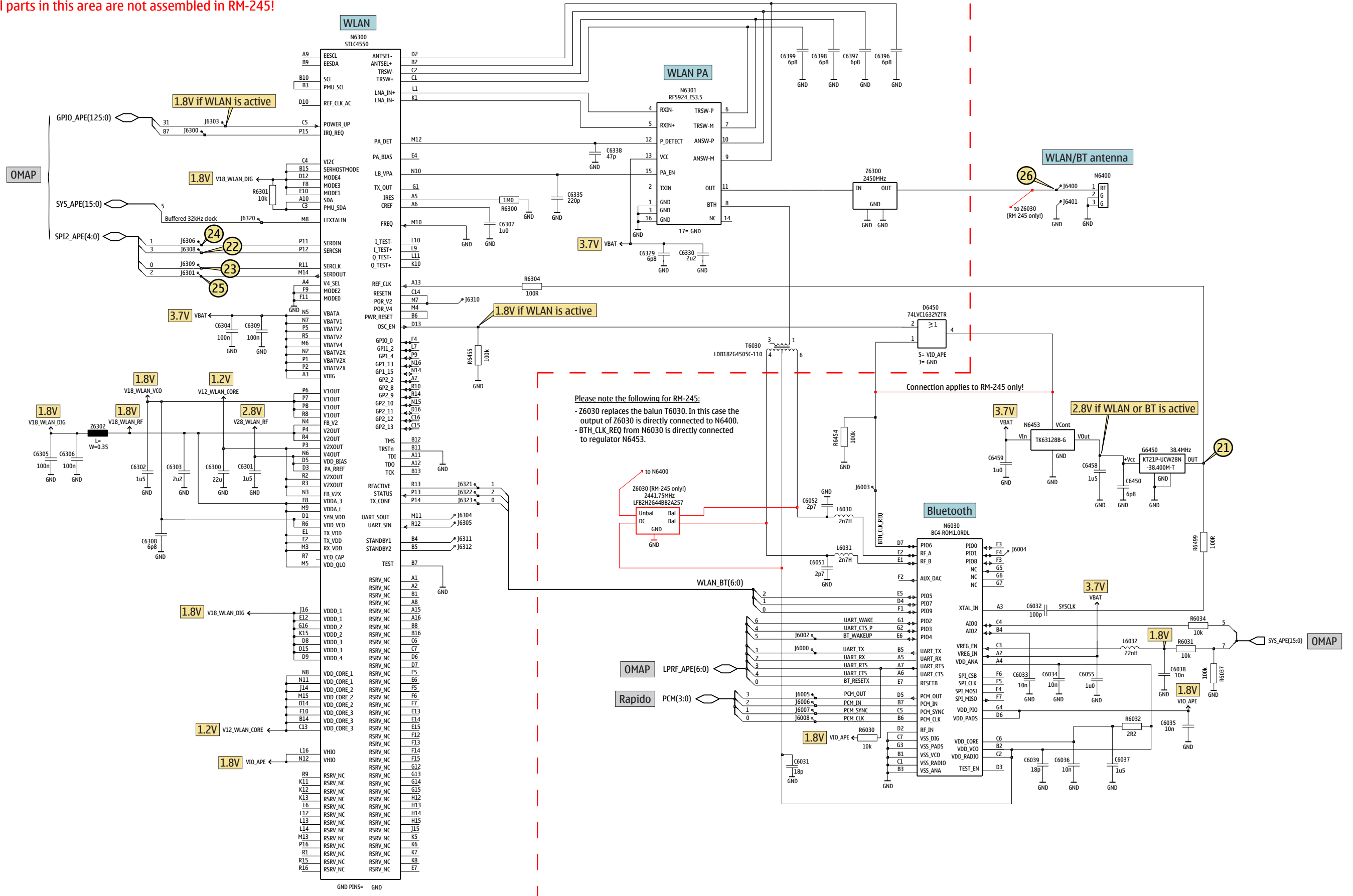



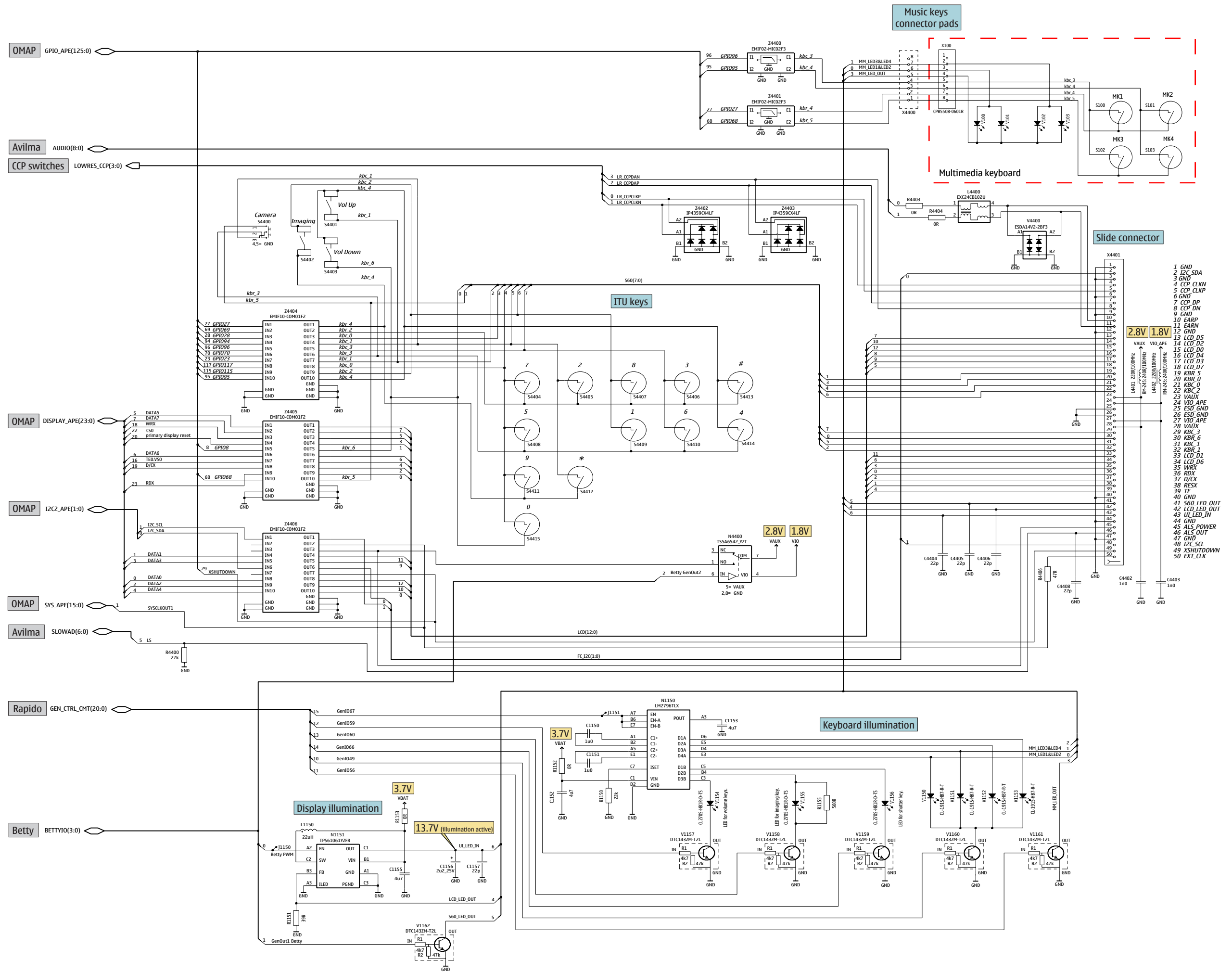

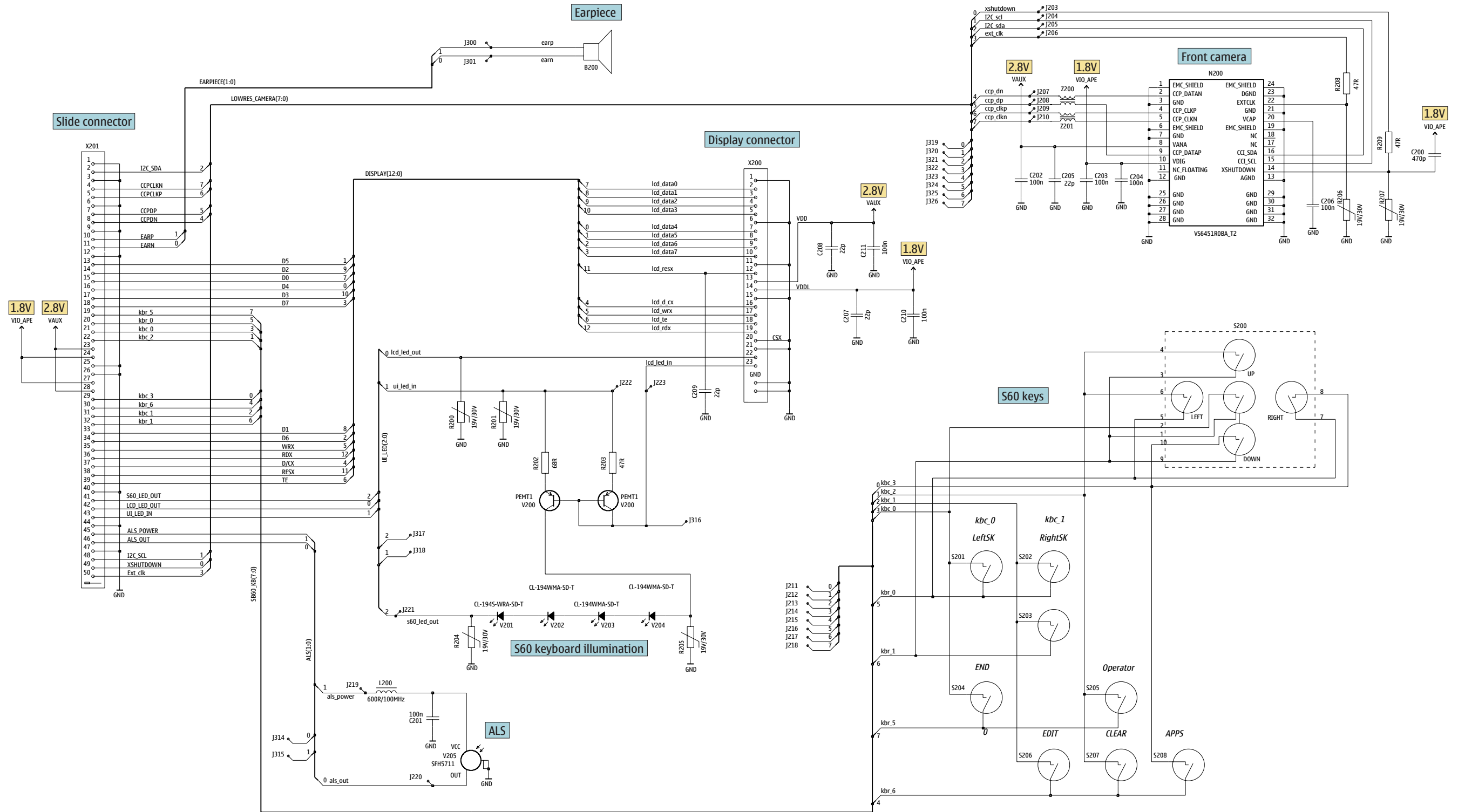



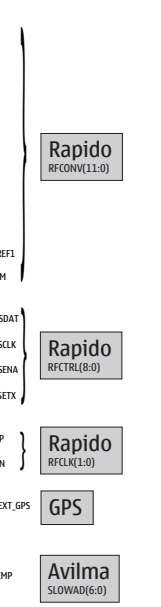
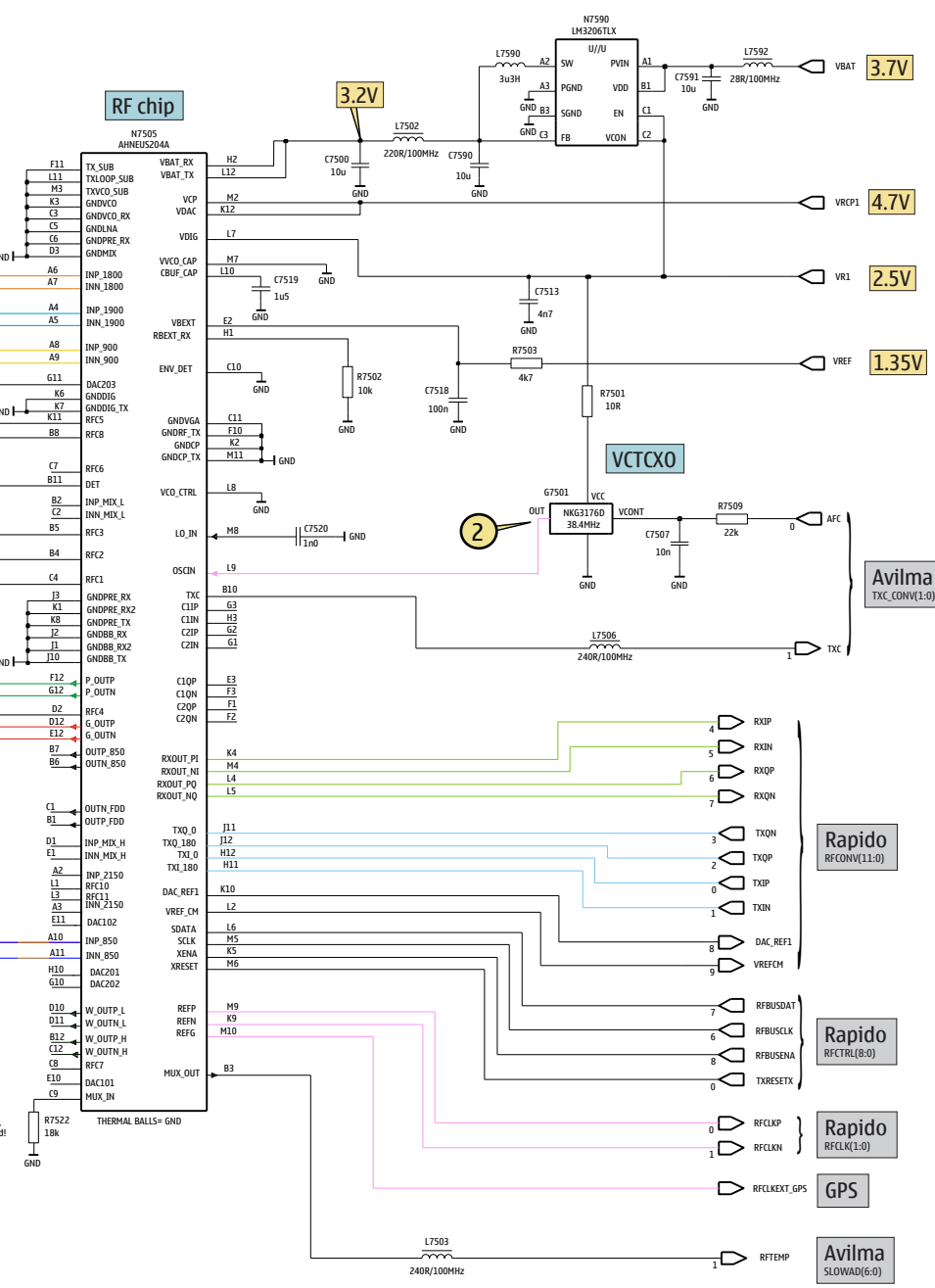
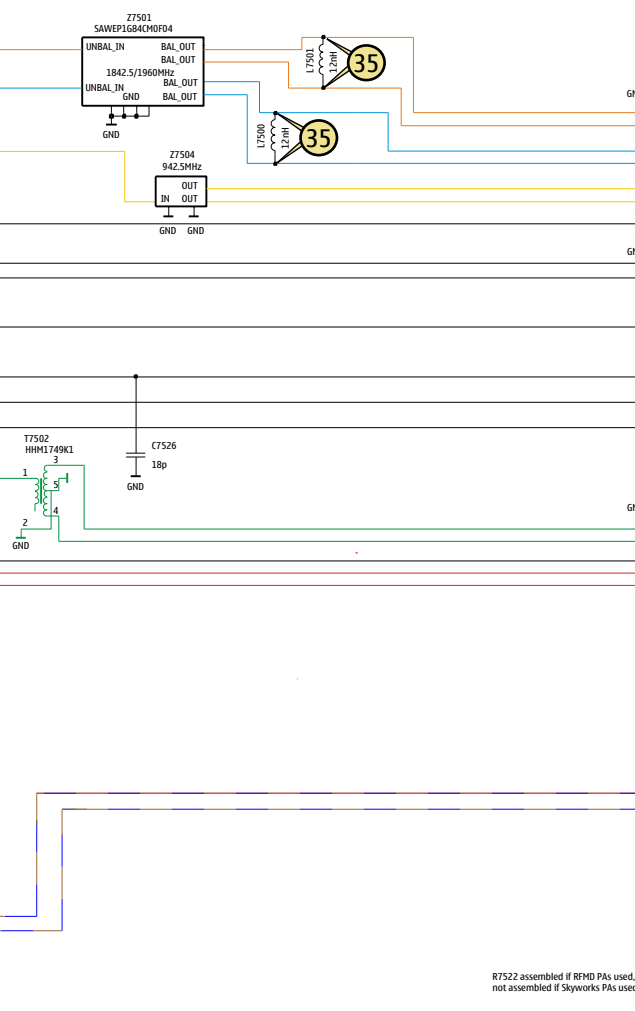
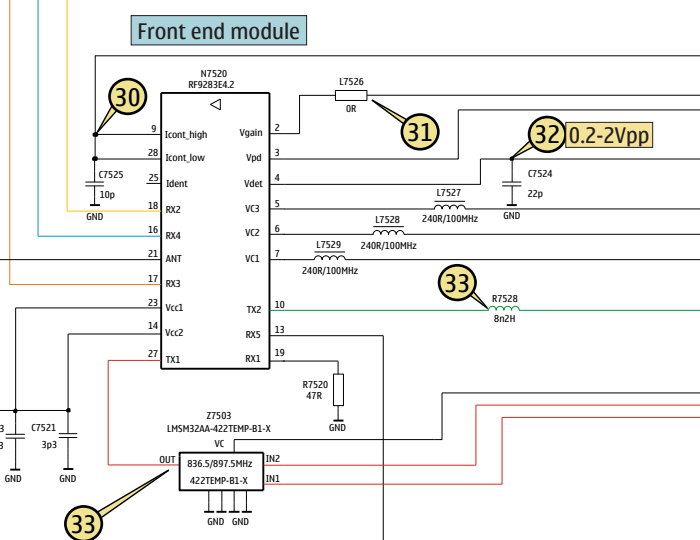
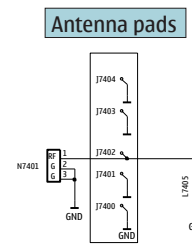

R7522 assembled if RFMD PAs used, not assembled if Skyworks PAs used!

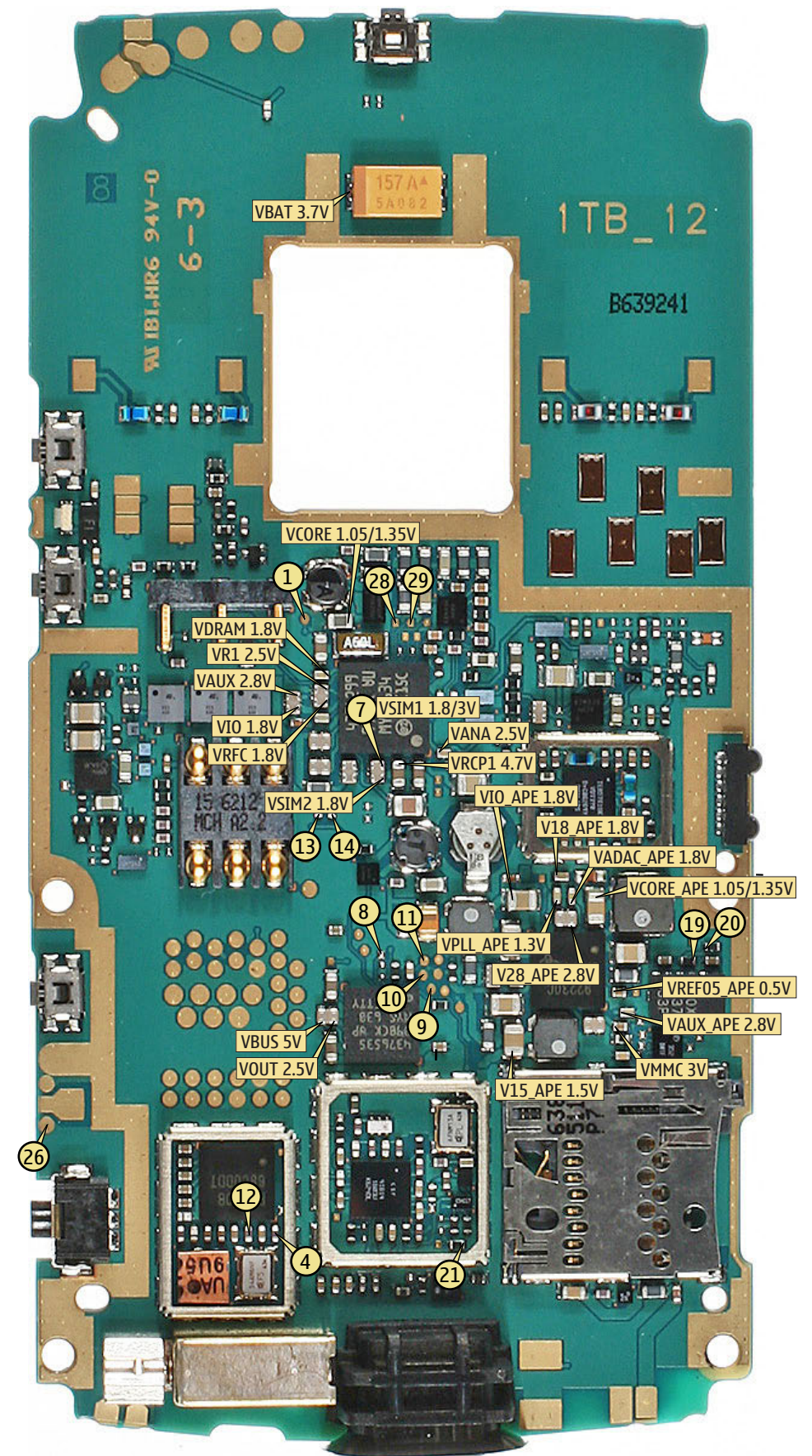
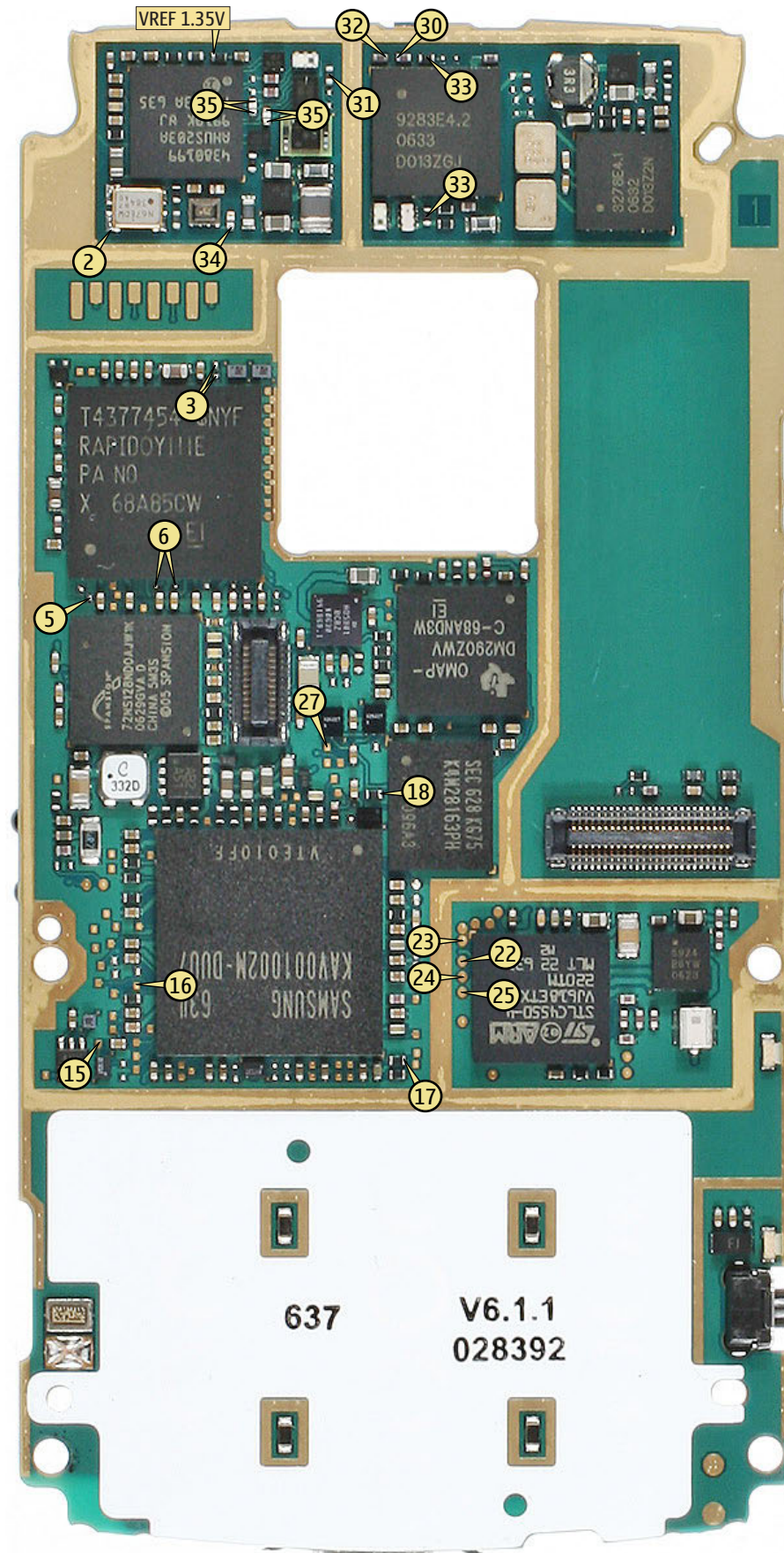
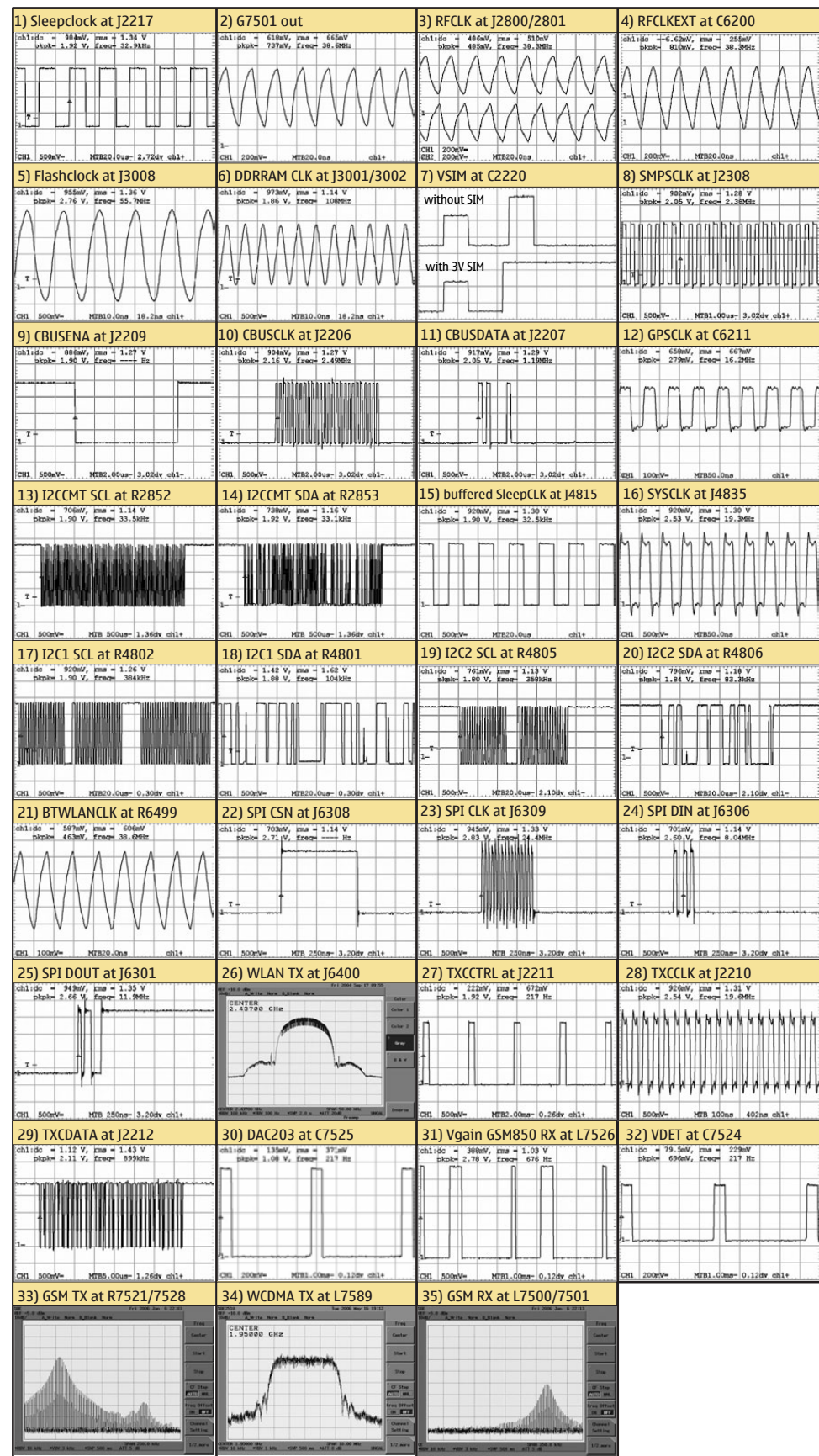

B	C2815	A14	C650	A7	E	A814	B7	J6321	G8	N6300	G7	R7522	C18		
B2100	C1	C2816	C14	C6031	F5	E2001	A13	J4815	B7	J6322	F8	N6301	I8	R7528	F17
B2101	B16	C2817	A15	C6032	E3	E2002	C13	J4816	C8	J6323	F8	N6453	D4	R7529	F17
B2102	I16	C2818	B15	C6033	E4	E2003	B12	J4817	C8	J6400	J5	N7505	C18	R7530	F17
B2200	F11	C2820	A13	C6034	E4	E2004	C12	J4818	D10	J6401	J6	N7520	F18	R7541	I19
C	C2821	C12	C6035	F4	E2005	B13	A819	D10	J7400	I19	N7540	F18	R7544	H18	
C1100	A7	C3000	A11	C6036	E3	E2006	B13	J4820	D10	J7401	H19	N7541	H19	R7544	H18
C1101	B7	C3001	A10	C6037	F3	F	A821	B8	J7402	I19	N7590	D17	R7560	G19	
C1102	I12	C3002	C11	C6038	F4	F2000	B3	J4822	D10	J7403	G19	R	S		
C1103	I13	C3003	A11	C6039	E4 <th>G</th> <th>A823</th> <th>B8</th> <th>J7404</th> <th>G19</th> <th>R1100</th> <th>I12</th> <th>S4400</th> <th>J4</th>	G	A823	B8	J7404	G19	R1100	I12	S4400	J4	
C1104	I5	C3004	B12	C6051	F4	G2200	D9	J4824	B9	L	R1101	E6	S4401	J14	
C1105	I5	C3005	C11	C6052	E4	G6200	G3	J4825	C7	L1150	E8	R1102	J5	S4402	J7
C1150	I10	C3006	C11	C6055	F5	G6450	E5	J4826	C7	L1404	I12	R1150	I9	S4403	J12
C1151	I9	C3007	A12	C6157	B9	G7501	B17	J4827	E6	L1405	H13	R1151	F8	S4416	E19
C1152	I10	C3008	A11	C6158	B9 <th>J</th> <th>A828</th> <th>E7</th> <th>L1406</th> <th>H12</th> <th>R1152</th> <th>I10</th> <th>T</th> <th></th> <th></th>	J	A828	E7	L1406	H12	R1152	I10	T		
C1153	I10	C4200	G6	C6159	C9	J1150	F8	J4829	B7	L1407	H13	R1153	E7	T6030	F5
C1155	E8	C4201	D7	C6161	C9	J1151	I9	J4830	E7	L1408	H12	R1155	B8	T7502	E17
C1156	E7	C4202	D6	C6162	B9	J2030	A13	J4831	F8	L2000	B3	R1402	H13	T7580	D19
C1157	E8	C4203	C8	C6163	B10	J2031	A11	J4832	F7	L2001	B11	R1403	H12	V	
C1400	D11	C4204	B7	C6164	C10	J2032	D15	J4833	B7	L2002	B11	R1404	H12	V1500	G2
C1401	C12	C4205	C8	C6165	C9	J2033	C11	J4834	F7	L2003	A11	R1405	I12	V1511	D2
C1402	C12	C4206	D6	C6170	B10	J2060	H6	J4835	B8	L2101	E12	R1406	H14	V1512	D5
C1404	I12	C4207	B7	C6174	C9	J2100	E12	J4836	B7	L2102	I14	R1407	H13	V1513	G5
C1405	H13	C4208	C8	C6176	C10	J2200	F11	J4837	F9	L2103	H14	R2000	B2	V1514	J13
C1407	G13	C4209	B7	C6178	C10	J2201	F10	J4838	B8	L2104	E12	R2002	B11	V1515	J7
C1408	I12	C4211	B6	C6179	B10	J2202	E9	J4839	C10	L2105	F3	R2003	B11	V1516	J4
C2000	C	C4212	C8	C6180	C9	J2203	F11	J4840	B8	L2106	F3	R2006	C11	V1517	J11
C2001	C	C4213	D7	C6182	C9	J2204	D13	J4842	D6	L2111	D12	R2009	B10	V1518	I9
C2002	B11	C4214	D7	C6184	C9	J2205	D14	J4843	D6	L2112	C14	R2010	B11	V1519	I9
C2004	C10	C4215	D7	C6185	C9	J2206	E7	J4844	D7	L2113	B14	R2012	A11	V1160	I9
C2005	C11	C4216	B8	C6200	G3	J2207	E7	J4845	D6	L2114	D12	R2030	D10	V1161	A15
C2007	B10	C4219	B7	C6201	H3	J2208	F11	J4846	D7	L2120	E12	R2031	D10	V1162	I11
C2008	B11	C4221	C8	C6202	H3	J2209	E7	J4847	C6	L2202	F9	R2032	D11	V1401	G12
C2009	B11	C4402	I10	C6203	H4	J2210	E11	J4848	D7	L2205	D10	R2033	D10	V4400	I10
C2012	C11	C4403	H9	C6204	H3	J2211	D11	J4849	B9	L2390	F12	R2071	D3	V4500	C10
C2013	B10	C4404	H9	C6205	G3	J2212	E11	J4850	F8	L2391	F12	R2106	I14	V4541	D10
C2014	C11	C4405	H10	C6206	H4	J2213	E9	J5100	G7	L4200	B7	R2107	H14	X	
C2018	C11	C4406	H9	C6207	H3	J2214	D10	J5101	H7	L4201	B7	R2116	B14	X1400	D11
C2019	C11	C4408	H9	C6209	H4	J2215	F10	J5102	H7	L4202	D6	R2117	B14	X1401	I13
C2030	E10	C4600	A10	C6210	H4	J2216	E7	J5103	H7	L4203	B8	R2120	D12	X2000	B1
C2033	E10	C4601	A9	C6211	G3	J2217	G12	J5104	G7	L4204	C6	R2121	E11	X2001	B13
C2071	E17	C4602	A9	C6212	H4	J2218	E7	J5105	H7	L4205	D7	R2200	D11	X2070	H12
C2072	F12	C4800	E8	C6300	H8	J2219	F7	J5106	H7	L4400	I10	R2300	G11	X2700	G9
C2073	H11	C4801	C7	C6301	G8	J2220	D15	J5107	G7	L4401	I10	R2852	F9	X3300	E1
C2106	H14	C4802	B9	C6302	G8	J2221	D15	J5108	H7	L4402	I10	R2853	F9	X4400	B16
C2107	H14	C4803	B8	C6303	H8	J2300	E7	J5109	G7	L4800	D10	R2862	C11	X4401	H9
C2108	F3	C4804	E8	C6304	I8	J2301	E7	J5113	G5	L5200	B6	R3000	E6	X5250	B4
C2109	F3	C4806	E9	C6305	F7	J2302	F7	J5114	G5	L5410	F13	R3300	E3	Z	
C2110	F3	C4807	D10	C6306	G8	J2308	F7	J5127	G5	L5450	B10	R3301	E3	Z2001	B11
C2116	B14	C4808	D10	C6307	G6 <th>J2800</th> <th>C15</th> <th>J5200</th> <th>B6</th> <th>L6030</th> <th>E4</th> <th>R4400</th> <th>E11</th> <th>Z3000</th> <th>E3</th>	J2800	C15	J5200	B6	L6030	E4	R4400	E11	Z3000	E3
C2117	B14	C4810	E10	C6308	H7	J2801	C15	J5201	A6	L6031	F4	R4403	H9	Z4400	D15
C2120	E12	C4814	D10	C6309	G8 <th>J2802</th> <th>A10</th> <th>J5202</th> <th>B6</th> <th>L6032</th> <th>F4</th> <th>R4404</th> <th>H9</th> <th>Z4401</th> <th>C15</th>	J2802	A10	J5202	B6	L6032	F4	R4404	H9	Z4401	C15
C2121	E12	C4816	D10	C6329	I8 <th>J2850</th> <th>A15</th> <th>J5203</th> <th>B6</th> <th>L6156</th> <th>B9</th> <th>R4406</th> <th>H10</th> <th>Z4402</th> <th>I10</th>	J2850	A15	J5203	B6	L6156	B9	R4406	H10	Z4402	I10
C2122	D12	C4817	D10	C6330	I8 <th>J3000</th> <th>B13</th> <th>J5204</th> <th>A6</th> <th>L6176</th> <th>C10</th> <th>R4600</th> <th>A9</th> <th>Z4403</th> <th>I10</th>	J3000	B13	J5204	A6	L6176	C10	R4600	A9	Z4403	I10
C2123	D11	C4818	C10	C6335	I8 <th>J3001</th> <th>B13</th> <th>J5205</th> <th>B6</th> <th>L6200</th> <th>H3</th> <th>R4601</th> <th>A10</th> <th>Z4404</th> <th>G10</th>	J3001	B13	J5205	B6	L6200	H3	R4601	A10	Z4404	G10
C2124	D11	C4819	B9	C6338	I8 <th>J3002</th> <th>C13</th> <th>J5206</th> <th>A6</th> <th>L6201</th> <th>H4</th> <th>R4800</th> <th>E8</th> <th>Z4405</th> <th>H10</th>	J3002	C13	J5206	A6	L6201	H4	R4800	E8	Z4405	H10
C2125	E11	C4820	E7	C6396 <td>H7<th>J3003</th><th>B12</th><th>J5400</th><th>E11</th><th>L7405</th><th>G18</th><th>R4801</th><th>E10</th><th>Z4406</th><th>H10</th></td>	H7 <th>J3003</th> <th>B12</th> <th>J5400</th> <th>E11</th> <th>L7405</th> <th>G18</th> <th>R4801</th> <th>E10</th> <th>Z4406</th> <th>H10</th>	J3003	B12	J5400	E11	L7405	G18	R4801	E10	Z4406	H10
C2126	E12	C4821	D7	C6397 <td>H7<th>J3004</th><th>D13</th><th>J5410</th><th>F7</th><th>L7500</th><th>C19</th><th>R4802</th><th>E7</th><th>Z5200</th><th>B6</th></td>	H7 <th>J3004</th> <th>D13</th> <th>J5410</th> <th>F7</th> <th>L7500</th> <th>C19</th> <th>R4802</th> <th>E7</th> <th>Z5200</th> <th>B6</th>	J3004	D13	J5410	F7	L7500	C19	R4802	E7	Z5200	B6
C2127	D12	C4822	B7	C6398 <td>H7<th>J3005</th><th>C13</th><th>J5411</th><th>F7</th><th>L7501</th><th>D18</th><th>R4804</th><th>B7</th><th>Z6200</th><th>H3</th></td>	H7 <th>J3005</th> <th>C13</th> <th>J5411</th> <th>F7</th> <th>L7501</th> <th>D18</th> <th>R4804</th> <th>B7</th> <th>Z6200</th> <th>H3</th>	J3005	C13	J5411	F7	L7501	D18	R4804	B7	Z6200	H3
C2128	E11	C4823	B8	C6399 <td>H7<th>J3006</th><th>C13</th><th>J5412</th><th>F8</th><th>L7502</th><th>C17</th><th>R4805</th><th>A7</th><th>Z6300</th><th>I7</th></td>	H7 <th>J3006</th> <th>C13</th> <th>J5412</th> <th>F8</th> <th>L7502</th> <th>C17</th> <th>R4805</th> <th>A7</th> <th>Z6300</th> <th>I7</th>	J3006	C13	J5412	F8	L7502	C17	R4805	A7	Z6300	I7
C2201	F10	C4824	B8	C6450 <td>E4<th>J3007</th><th>B12</th><th>J5413</th><th>G10</th><th>L7503</th><th>C19</th><th>R4806</th><th>A7</th><th>Z7501</th><th>D19</th></td>	E4 <th>J3007</th> <th>B12</th> <th>J5413</th> <th>G10</th> <th>L7503</th> <th>C19</th> <th>R4806</th> <th>A7</th> <th>Z7501</th> <th>D19</th>	J3007	B12	J5413	G10	L7503	C19	R4806	A7	Z7501	D19
C2202	D11	C4825	E7	C6458 <td>D4<th>J3008</th><th>A12</th><th>J5414</th><th>F11</th><th>L7506</th><th>C17</th><th>R5001</th><th>B9</th><th>Z7503</th><th>D18</th></td>	D4 <th>J3008</th> <th>A12</th> <th>J5414</th> <th>F11</th> <th>L7506</th> <th>C17</th> <th>R5001</th> <th>B9</th> <th>Z7503</th> <th>D18</th>	J3008	A12	J5414	F11	L7506	C17	R5001	B9	Z7503	D18
C2203	D11	C4826	E7	C6459 <td>E4<th>J3009</th><th>F12</th><th>J5450</th><th>E12</th><th>L7510</th><th>F17</th><th>R5002</th><th>C10</th><th>Z7504</th><th>D18</th></td>	E4 <th>J3009</th> <th>F12</th> <th>J5450</th> <th>E12</th> <th>L7510</th> <th>F17</th> <th>R5002</th> <th>C10</th> <th>Z7504</th> <th>D18</th>	J3009	F12	J5450	E12	L7510	F17	R5002	C10	Z7504	D18
C2205	E11	C4827	F8	C7500 <td>B18<th>J3010</th><th>A13</th><th>J5451</th><th>F12</th><th>L7526</th><th>D19</th><th>R5003</th><th>B9</th><th>Z7521</th><th>E17</th></td>	B18 <th>J3010</th> <th>A13</th> <th>J5451</th> <th>F12</th> <th>L7526</th> <th>D19</th> <th>R5003</th> <th>B9</th> <th>Z7521</th> <th>E17</th>	J3010	A13	J5451	F12	L7526	D19	R5003	B9	Z7521	E17
C2211	E9	C4828	E7	C7507 <td>C18<th>J3011</th><th>C13</th><th>J5500</th><th>D14</th><th>L7540</th><th>G19</th><th>R5004</th><th>B9</th><th>Z7540</th><th>G17</th></td>	C18 <th>J3011</th> <th>C13</th> <th>J5500</th> <th>D14</th> <th>L7540</th> <th>G19</th> <th>R5004</th> <th>B9</th> <th>Z7540</th> <th>G17</th>	J3011	C13	J5500	D14	L7540	G19	R5004	B9	Z7540	G17
C2213	F10	C4830	D7	C7513 <td>B18<th>J3100</th><th>G6</th><th>J5501</th><th>B8</th><th>L7550</th><th>I19</th><th>R5400</th><th>C10</th><th>Z7541</th><th>G18</th></td>	B18 <th>J3100</th> <th>G6</th> <th>J5501</th> <th>B8</th> <th>L7550</th> <th>I19</th> <th>R5400</th> <th>C10</th> <th>Z7541</th> <th>G18</th>	J3100	G6	J5501	B8	L7550	I19	R5400	C10	Z7541	G18
C2215	F10	C4832	B7	C7518 <td>C19<th>J3101</th><th>G6</th><th>J5502</th><th>A8</th><th>L7588</th><th>C18</th><th>R5401</th><th>C10</th><th>Z7580</th><th>D19</th></td>	C19 <th>J3101</th> <th>G6</th> <th>J5502</th> <th>A8</th> <th>L7588</th> <th>C18</th> <th>R5401</th> <th>C10</th> <th>Z7580</th> <th>D19</th>	J3101	G6	J5502	A8	L7588	C18	R5401	C10	Z7580	D19
C2216	F11	C4833	B8	C7519 <td>B19<th>J3102</th><th>G7</th><th>J5503</th><th>B8</th><th>L7589</th><th>C17</th><th>R5410</th><th>F13</th><th>Z7582</th><th>C17</th></td>	B19 <th>J3102</th> <th>G7</th> <th>J5503</th> <th>B8</th> <th>L7589</th> <th>C17</th> <th>R5410</th> <th>F13</th> <th>Z7582</th> <th>C17</th>	J3102	G7	J5503	B8	L7589	C17	R5410	F13	Z7582	C17
C2217	E10	C4834	E9	C7520 <td>B19<th>J3103</th><th>G7</th><th>J5504</th><th>B8</th><th>L7590</th><th>D17</th><th>R5411</th><th>E13</th><th></th><th></th></td>	B19 <th>J3103</th> <th>G7</th> <th>J5504</th> <th>B8</th> <th>L7590</th> <th>D17</th> <th>R5411</th> <th>E13</th> <th></th> <th></th>	J3103	G7	J5504	B8	L7590	D17	R5411	E13		
C2220	F9	C4835	E8	C7521	F19 <th>J3104</th> <th>G6</th> <th>J5505</th> <th>B8</th> <th>L7591</th> <th>H19</th> <th>R5412</th> <th>F13</th> <th></th> <th></th>	J3104	G6	J5505	B8	L7591	H19	R5412	F13		
C2222	E9	C4836	E7	C7523	F17 <th>J3105</th> <th>G7</th> <th>J5506</th> <th>B8</th> <th>L7592</th> <th>D18</th> <th>R5413</th> <th>E12</th> <th></th> <th></th>	J3105	G7	J5506	B8	L7592	D18	R5413	E12		
C2225	E9	C5200	B6	C7524	E19 <th>J3106</th> <th>G7</th> <th>J5507</th> <th>B8</th> <th>L7597</th> <th>B8</th> <th>R5414</th> <th>E12</th> <th></th> <th></th>	J3106	G7	J5507	B8	L7597	B8	R5414	E12		
C2226	F11	C5201	B6	C7525	E19 <th>J3107</th> <th>H5</th> <th>J5508</th> <th>A6</th> <th>L2100</th> <th>G2</th> <th>R5415</th> <th>E12</th> <th></th> <th></th>	J3107	H5	J5508	A6	L2100	G2	R5415	E12		
C2227	F10	C5390	C7	C7543 <td>H18<th>J3108</th><th>H5</th><th>J6000</th><th>E3</th><th>N</th><th>R5452</th><th>B10</th><th></th><th></th><th></th></td>	H18 <th>J3108</th> <th>H5</th> <th>J6000</th> <th>E3</th> <th>N</th> <th>R5452</th> <th>B10</th> <th></th> <th></th> <th></th>	J3108	H5	J6000	E3	N	R5452	B10			
C2228	F10	C5400	E11	C7544 <td>H18<th>J3109</th><th>H5</th><th>J6002</th><th>F4</th><th>N1100</th><th>A6</th><th>R5453</th><th>B10</th><th></th><th></th></td>	H18 <th>J3109</th> <th>H5</th> <th>J6002</th> <th>F4</th> <th>N1100</th> <th>A6</th> <th>R5453</th> <th>B10</th> <th></th> <th></th>	J3109	H5	J6002	F4	N1100	A6	R5453	B10		
C2231	D9	C5402	E10	C7545 <td>H18<th>J3110</th><th>G7</th><th>J6004</th><th>F5</th><th>N1101</th><th>I13</th><th>R5455</th><th>E12</th><th></th><th></th></td>	H18 <th>J3110</th> <th>G7</th> <th>J6004</th> <th>F5</th> <th>N1101</th> <th>I13</th> <th>R5455</th> <th>E12</th> <th></th> <th></th>	J3110	G7	J6004	F5	N1101	I13	R5455	E12		
C2232	F9	C5410	G13	C7547 <td>H19<th>J3111</th><th>H5</th><th>J6005</th><th>D14</th><th>N1102</th><th>I4</th><th>R5650</th><th>A7</th><th></th><th></th></td>	H19 <th>J3111</th> <th>H5</th> <th>J6005</th> <th>D14</th> <th>N1102</th> <th>I4</th> <th>R5650</th> <th>A7</th> <th></th> <th></th>	J3111	H5	J6005	D14	N1102	I4	R5650	A7		
C2300	E6	C5411	G13	C7548 <td>I18<th>J3112</th><th>H5</th><th>J6006</th><th>D14</th><th>N1150</th><th>I9</th><th>R6030</th><th>E3</th><th></th><th></th></td>	I18 <th>J3112</th> <th>H5</th> <th>J6006</th> <th>D14</th> <th>N1150</th> <th>I9</th> <th>R6030</th> <th>E3</th> <th></th> <th></th>	J3112	H5	J6006	D14	N1150	I9	R6030	E3		
C2303	F7	C5412	F13	C7549 <td>G18<th>J3113</th><th>H5</th><th>J6007</th><th>D14</th><th>N1151</th><th>F8</th><th>R6031</th><th>F5</th><th></th><th></th></td>	G18 <th>J3113</th> <th>H5</th> <th>J6007</th> <th>D14</th> <th>N1151</th> <th>F8</th> <th>R6031</th> <th>F5</th> <th></th> <th></th>	J3113	H5	J6007	D14	N1151	F8	R6031	F5		
C2304	E7	C5413	F13	C7550 <td>I18<th>J3114</th><th>G5</th><th>J6008</th><th>E4</th><th>N2000</th><th>C10</th><th>R6032</th><th>F3</th><th></th><th></th></td>	I18 <th>J3114</th> <th>G5</th> <th>J6008</th> <th>E4</th> <th>N2000</th> <th>C10</th> <th>R6032</th> <th>F3</th> <th></th> <th></th>	J3114	G5	J6008	E4	N2000	C10	R6032	F3		
C2307	F6	C5414	E11	C7553 <td>G18<th>J3300</th><th>G3</th><th>J6201</th><th>H5</th><th>N2001</th><th>C11</th><th>R6034</th><th>E5</th><th></th><th></th></td>	G18 <th>J3300</th> <th>G3</th> <th>J6201</th> <th>H5</th> <th>N2001</th> <th>C11</th> <th>R6034</th> <th>E5</th> <th></th> <th></th>	J3300	G3	J6201	H5	N2001	C11	R6034	E5		
C2312	F6	C5415	G11	C7580 <td>B19<th>J4400</th><th>G5</th><th>J6202</th><th>G4</th><th>N2002</th><th>C11</th><th>R6037</th><th>E7</th><th></th><th></th></td>	B19 <th>J4400</th> <th>G5</th> <th>J6202</th> <th>G4</th> <th>N2002</th> <th>C11</th> <th>R6037</th> <th>E7</th> <th></th> <th></th>	J4400	G5	J6202	G4	N2002	C11	R6037	E7		
C2390	F12	C5416	E12	C7581	B19 <th>J4401</th> <th>G5</th> <th>J6203</th> <th>G4</th> <th>N2030</th> <th>D10</th> <th>R6038</th> <th>E4</th> <th></th> <th></th>	J4401	G5	J6203	G4	N2030	D10	R6038	E4		
C2391	F11	C5417	E11	C7582	B19 <th>J4600</th> <th>A9</th> <th>J6204</th> <th>A15</th> <th>N2031</th> <th>D10</th> <th>R6159</th> <th>B9</th> <th></th> <th></th>	J4600	A9	J6204	A15	N2031	D10	R6159	B9		
C2700	H10	C5418	E11	C7583	B19 <th>J4601</th> <th>B9</th> <th>J6210</th> <th>I2</th> <th>N2120</th> <th>E12</th> <th>R6160</th> <th>B9</th> <th></th> <th></th>	J4601	B9	J6210	I2	N2120	E12	R6160	B9		
C2800	B12	C5419	F11	C7586	D19 <th>J4602</th> <th>A7</th> <th>J6211</th> <th>I1</th> <th>N2200</th> <th>F10</th> <th>R6161</th> <th>C9</th> <th></th> <th></th>	J4602	A7	J6211	I1	N2200	F10	R6161	C9		
C2801	C12	C5420	G11	C7587	D19 <th>J4800</th> <th>E6</th> <th>J6212</th> <th>I1</th> <th>N2300</th> <th>F6</th> <th>R6162</th> <th>B9</th> <th></th> <th></th>	J4800	E6	J6212	I1	N2300	F6	R6162	B9		
C2802	C14	C5421	F11	C7590	D17 <th>J4801</th> <th>C6</th> <th>J6213</th> <th>I1</th> <th>N2390</th> <th>F12</th> <th>R6174</th> <th>D10</th> <th></th> <th></th>	J4801	C6	J6213	I1	N2390	F12	R6174	D10		
C2803	A14	C5450	E13	C7591	D18 <th>J4802</th> <th>B7</th> <th>J6300</th> <th>F8</th> <th>N4200</th> <th>C7</th> <th>R6175</th> <th>D10</th> <th></th> <th></th>	J4802	B7	J6300	F8	N4200	C7	R6175	D10		
C2804	C12	C5451	D12 <th>D</th> <th>J4803</th> <th>B7</th> <th>J6301</th> <th>F7</th> <th>N4400</th> <th>I8</th> <th>R6300</th> <th>H6</th> <th></th> <th></th> <th></th>	D	J4803	B7	J6301	F7	N4400	I8	R6300	H6			
C2805	A13	C5452	D12	D2800	B14	J4804	F8	J6303	F7	N4600	A9	R6301	H6		
C2806	B15	C5453	A10	D3000	B11	J4805	C7	J6304	G8	N4801	E10	R6304	D5		
C2807	C15	C5454	D10	D4800	D8	J4806	B7	J6305	G8	N5400	E11	R6454	E3		
C2808	B15	C5455	D10	D5000	D8	J4807	B7	J6306	F8	N5401	D11	R6455	D3		
C2809	B15	C5456	C10	D5390	C7	J4808	E10	J6308	F8	N5451	C10	R6499	E3		
C2810	D12	C5457	C10	D5410	F12	J4809	E10	J6309	F8	N5452	E12	R7501	B18		
C2811	C12	C5461	C10	D5411	F10	J4810	D10	J6310	F6	N5650	A7	R7502	B19		
C2812	C15	C5463	E12	D5500	B7	J4811	F9	J6311	H7	N6030	F4	R7503	C19		
C2813	B12	C5464	D11	D6450	D4										

